



Focke-Wulf Ta 152H-1

1/32 scale

Pacific Coast Models, Inc.

613 Martin Ave., Bldg. 106
Rohnert Park, CA, USA 94928-2000
e-mail: info@pacmodels.com
www.pacmodels.com

The Focke-Wulf Ta-152H-1

The culmination of the Focke-Wulf FW-190 series fighter program, the 152H-1 was a high altitude version of the Ta-152C medium and low altitude fighter. The most striking visual difference between the two was the wing span. The C version had a wing span of 36' 1" while the H version's wing spanned 47' 6 3/4". It had a maximum altitude rating of over 48,000 feet and was powered by a Junkers Jumo 213E/B 12 cylinder inverted-vee liquid cooled engine. It had a top speed exceeding 470 mph enabling it to fly away from any Allied fighter.

Weapons included 1 x 30mm MK 108 cannon and 2 x 20mm MG 151 cannons. In my opinion, had it reached quantity production, it would have been used to attack Allied bomber and fighter formations from a superior altitude and then climb to repeat the attack. With this tactic, it would have been very difficult to stop.

This is our first kit of a German aircraft. We selected it, not only because of its' performance and uniqueness, but also because of the beauty of its' design. The only feature breaking its' symmetry is the large air intake on the right hand side. We hope that you like it.

I want to thank those whose help was essential in completing this project. From Great Britain, Chris Busbridge who designed the decals. From Malta, Richard Caruana who designed the color painting instructions. From the USA, Dan Zoernig who designed the box art. From Italy, Cartograf who printed the decals and painting instructions. Eduard of the Czech Republic for the PE set and Sword who produced the kit. Last, thanks to all of you who have supported Pacific Coast Models, Inc. and bought our kits.

Sincerely,

Ken & Mary Ellen Lawrence
Pacific Coast Models, Inc.

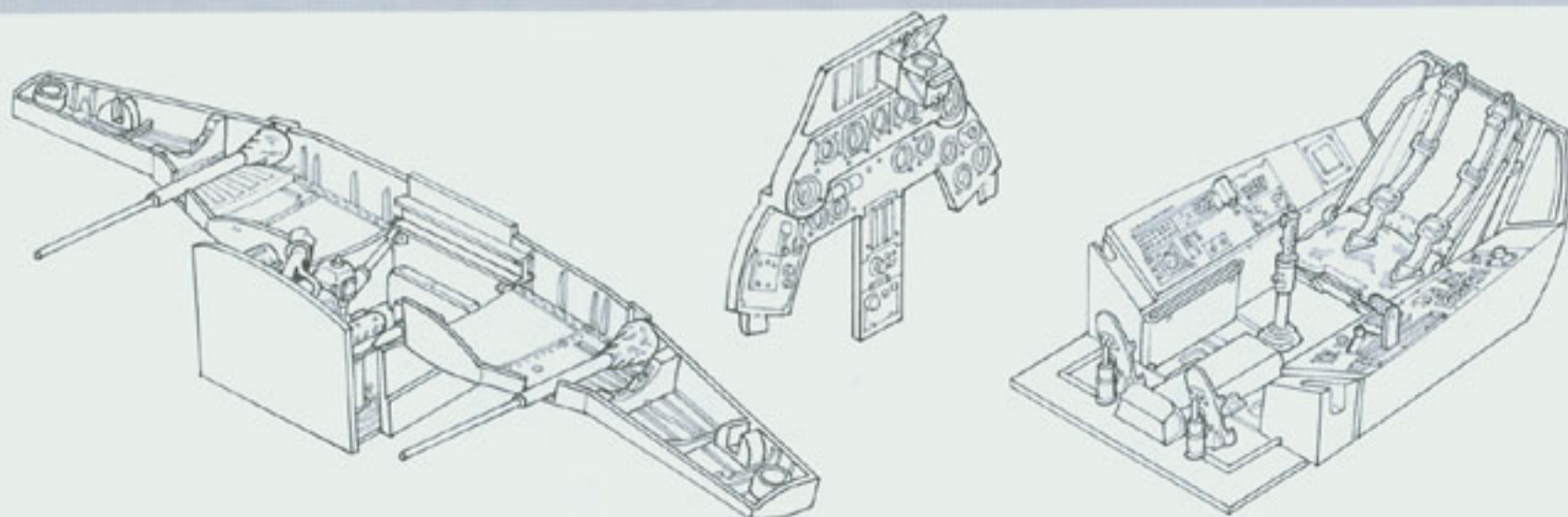

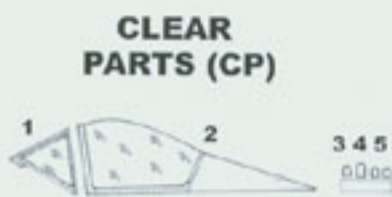
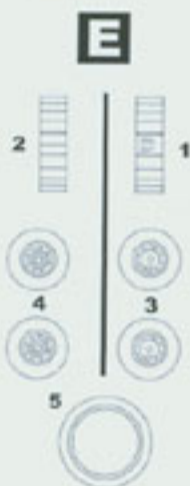
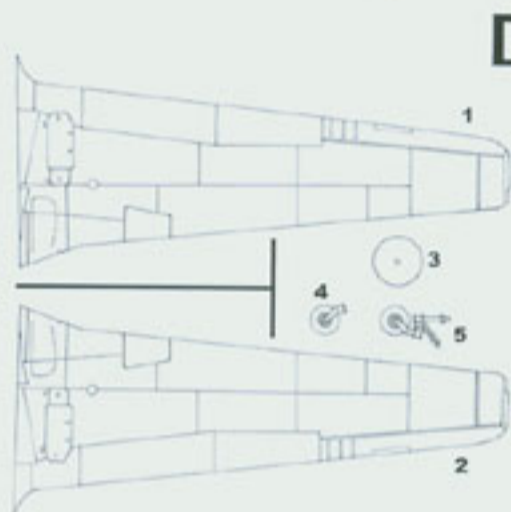
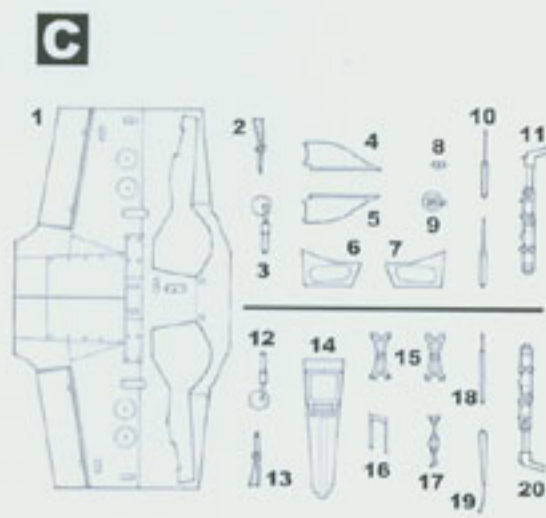
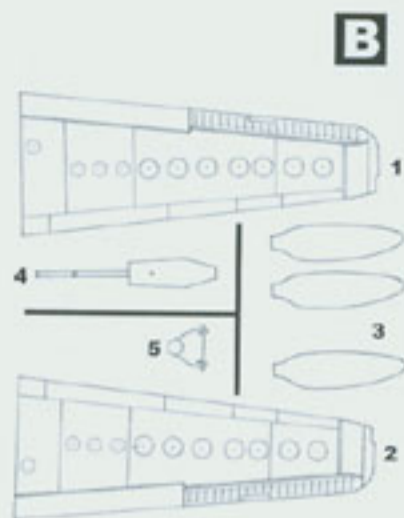
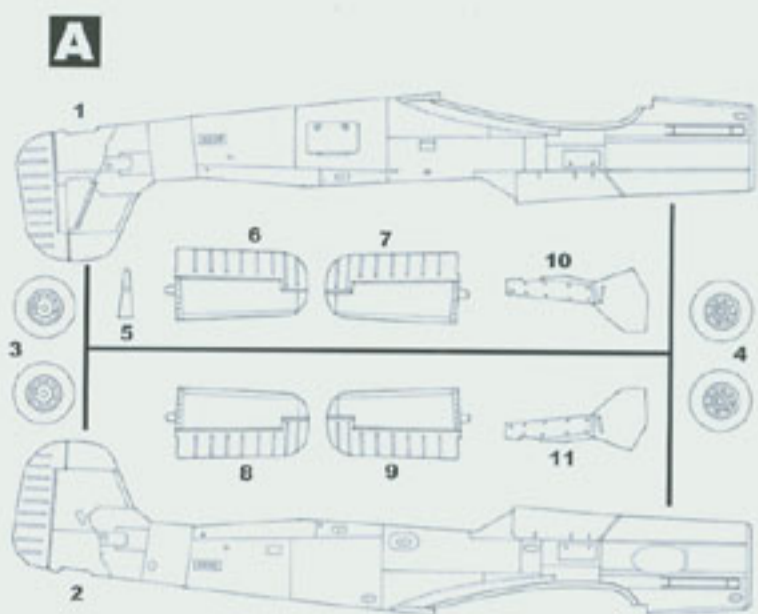
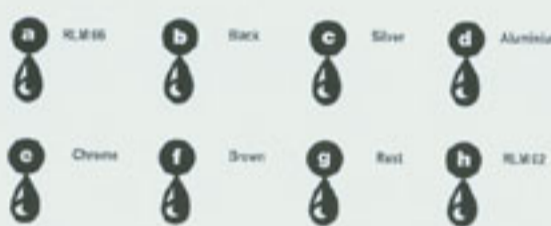
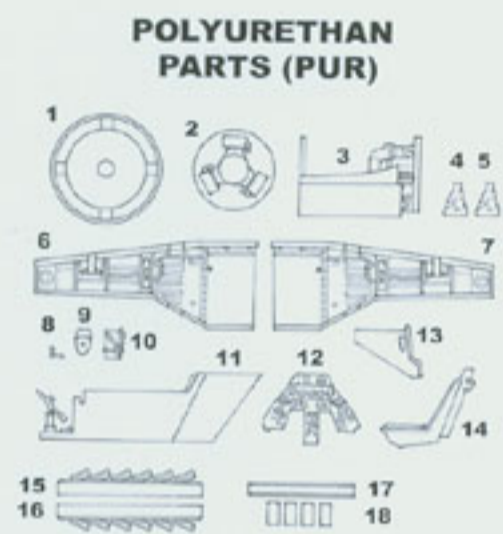
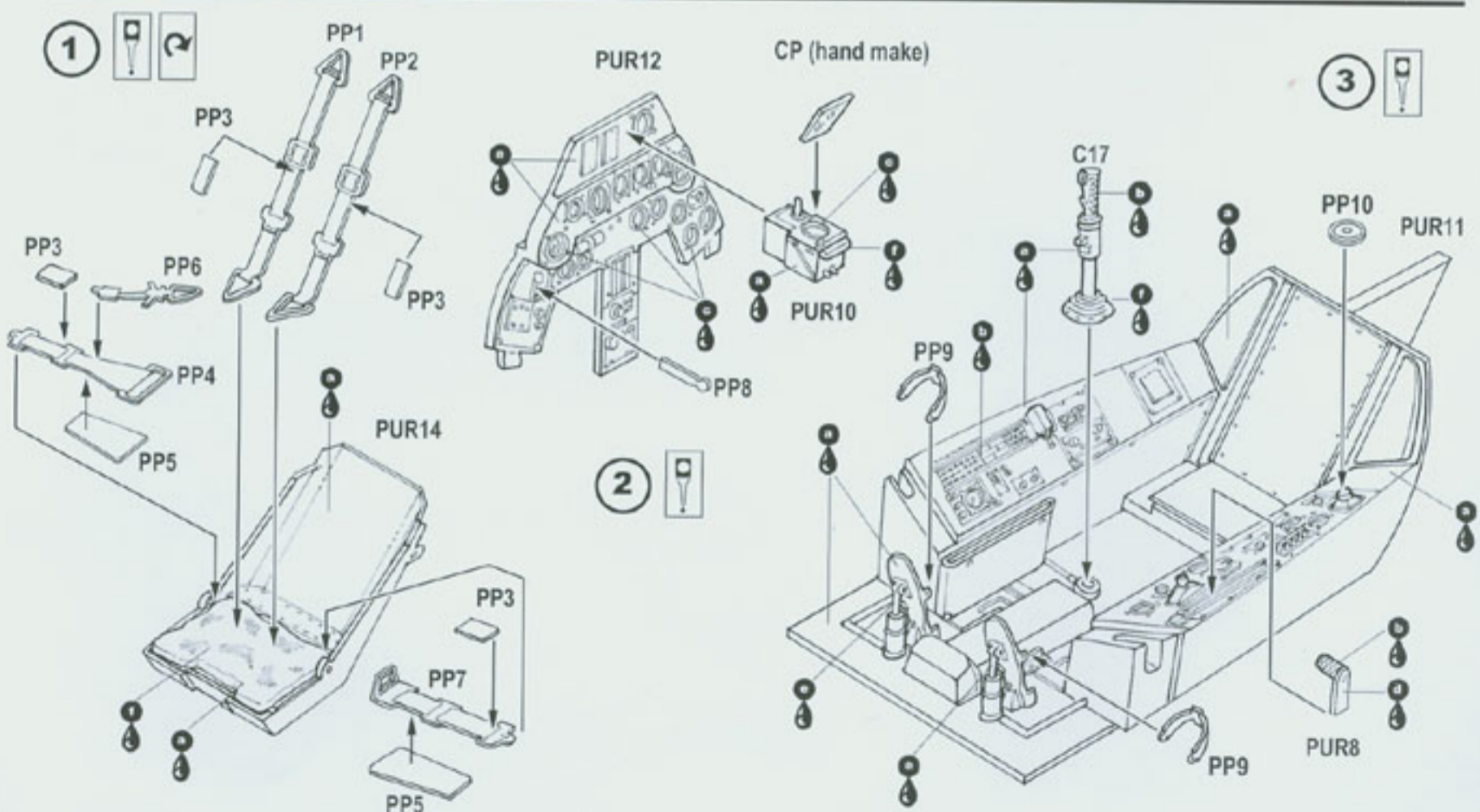

PHOTO-ETCHED PARTS (PP)



COLOR

LEGEND



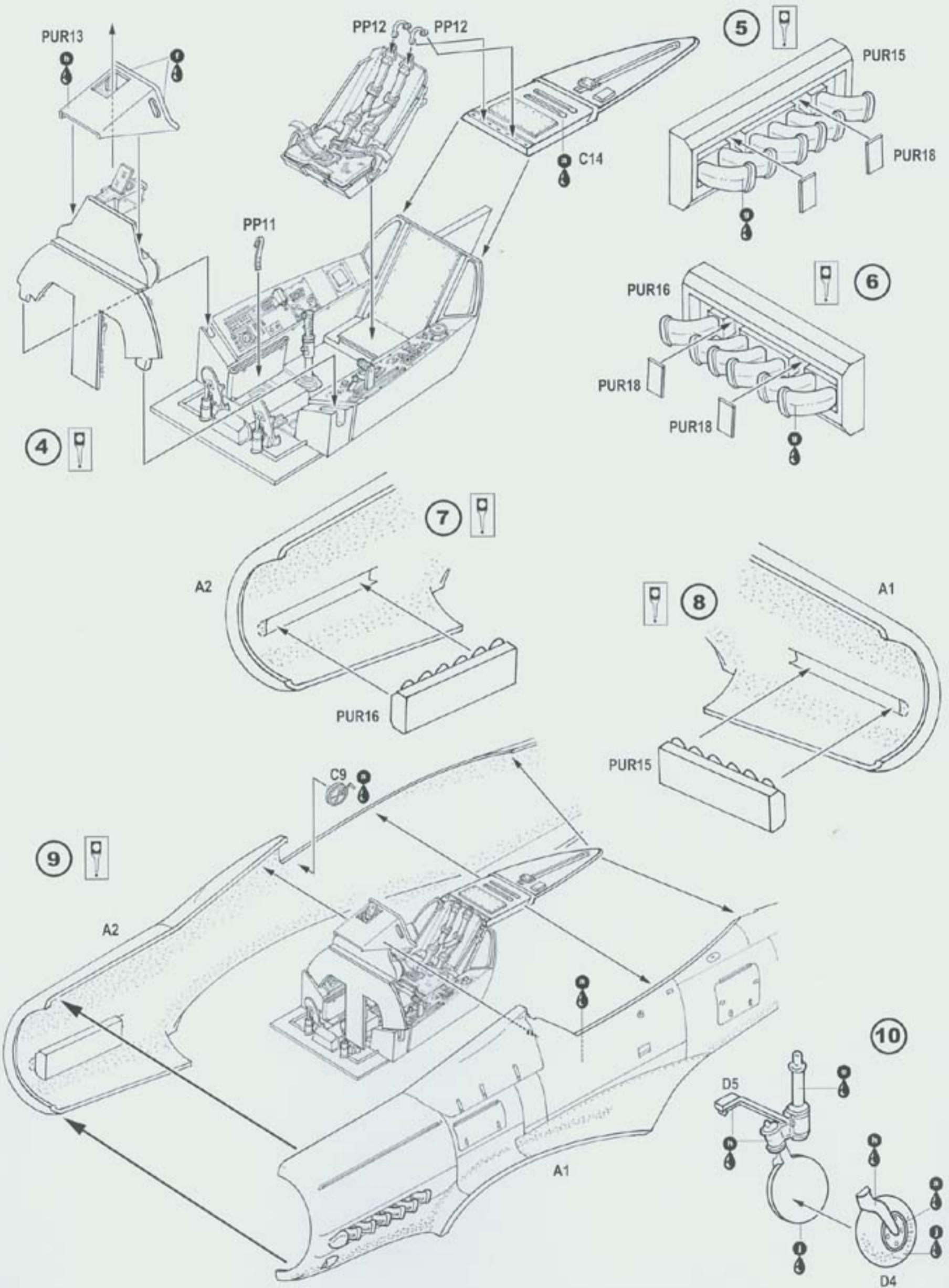

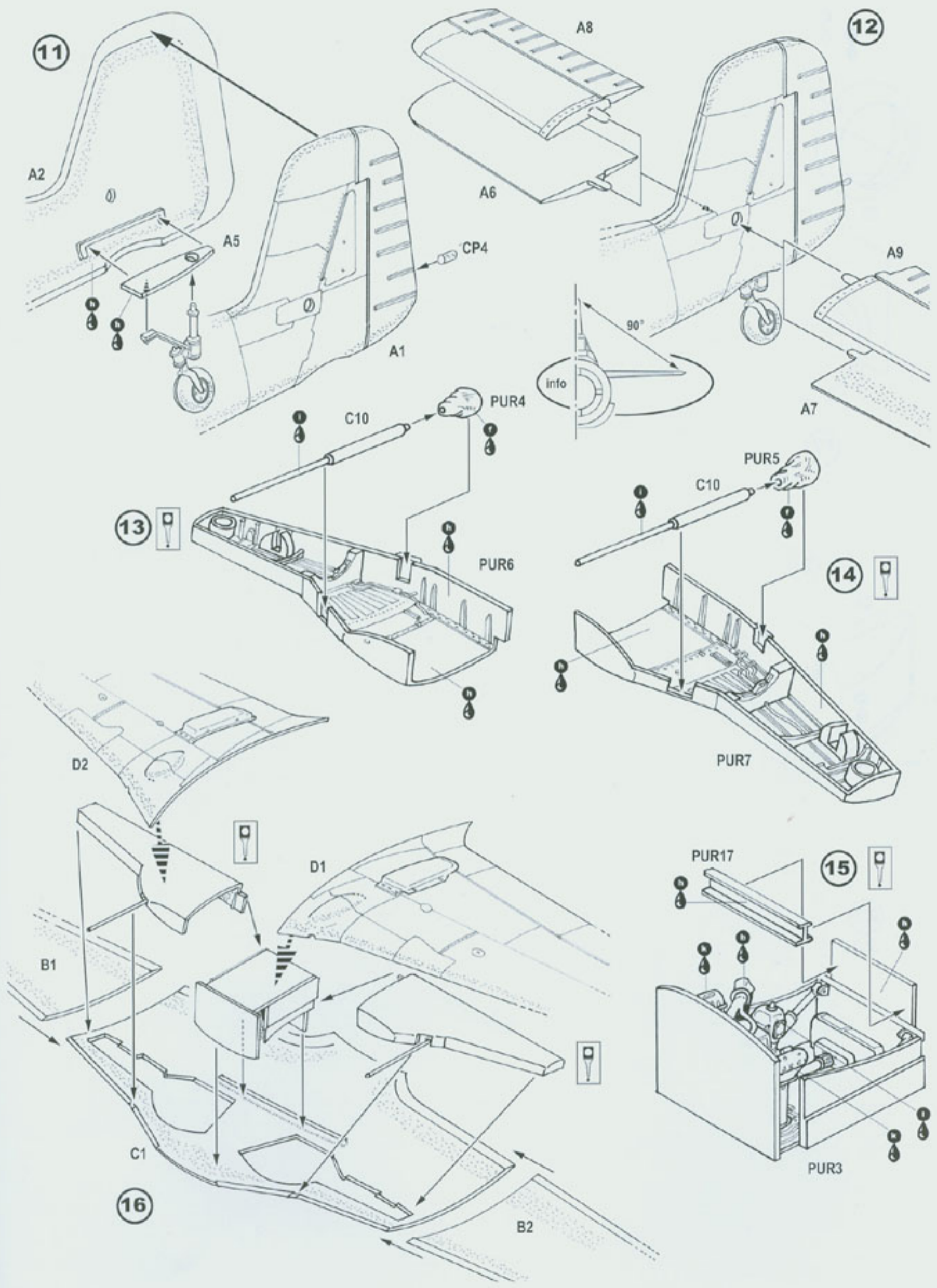

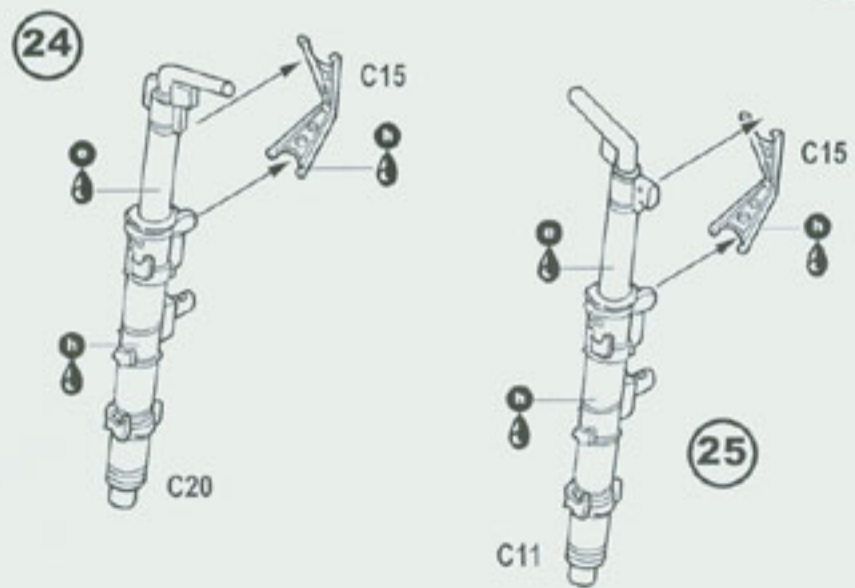
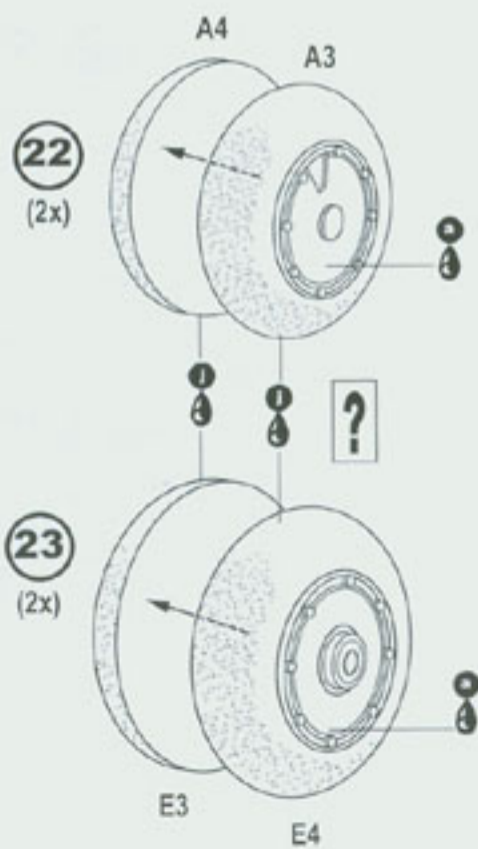
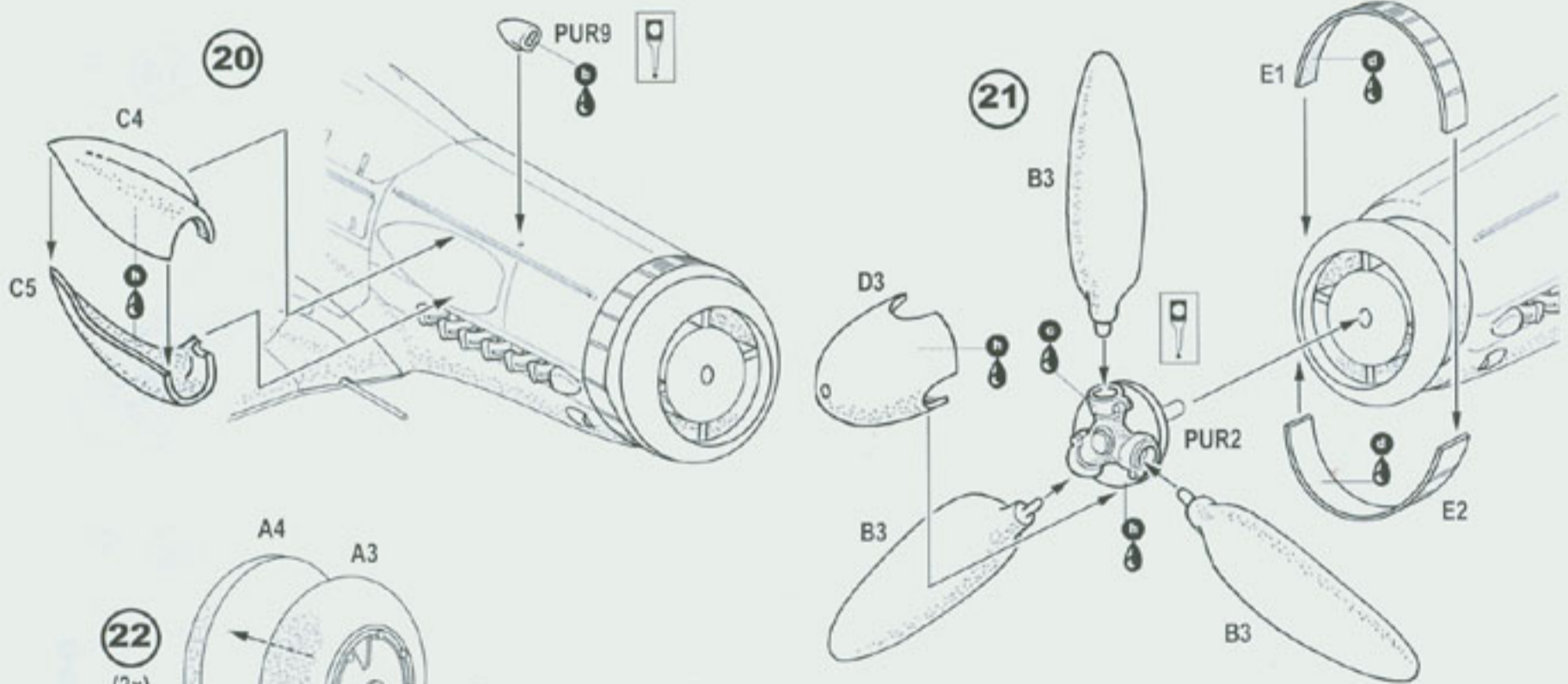
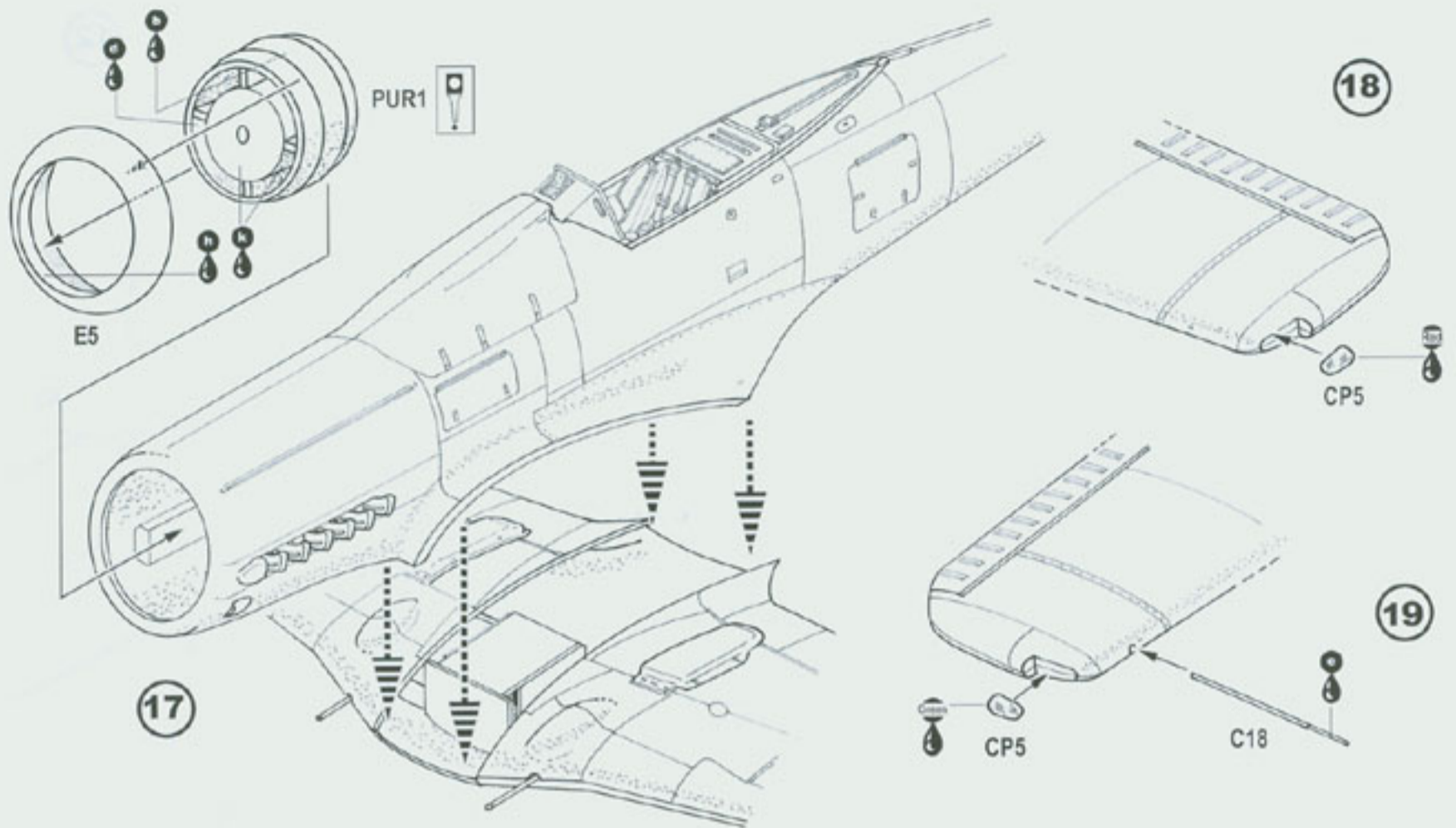

26

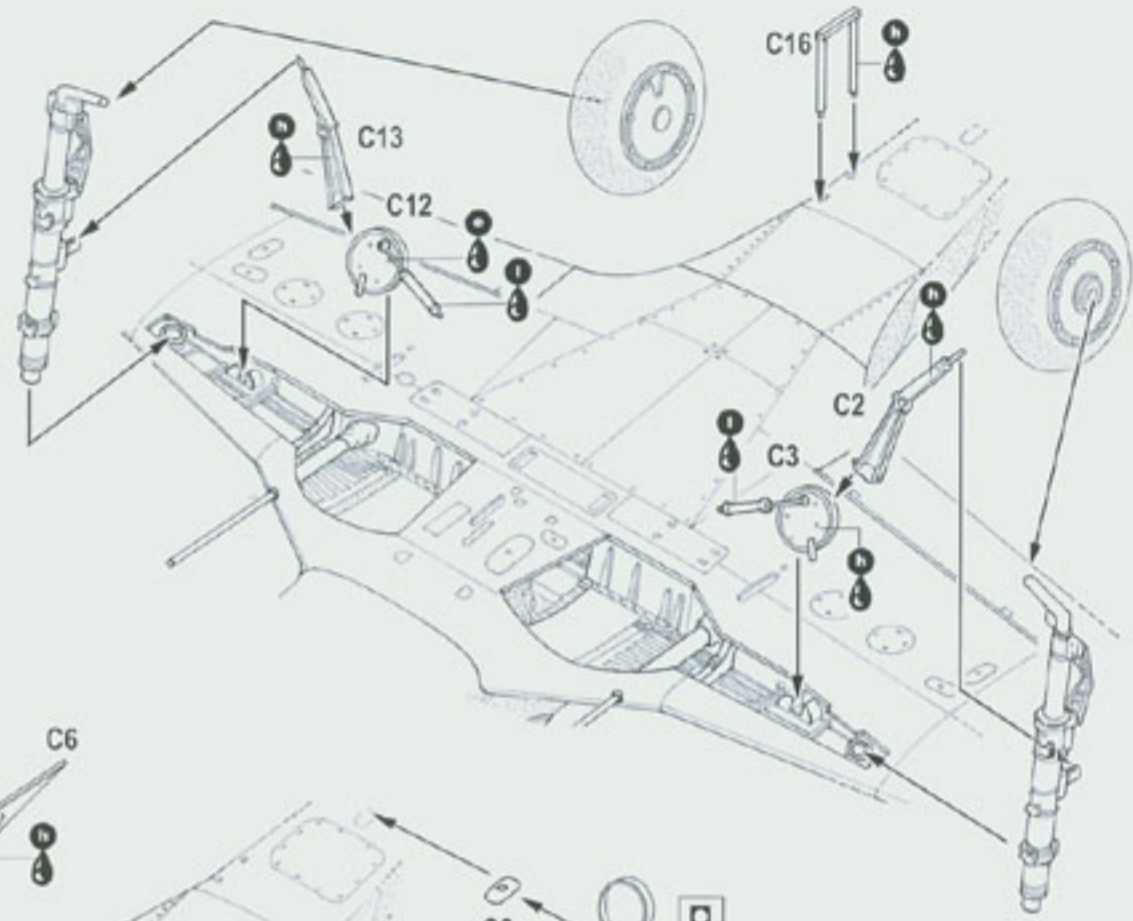

27

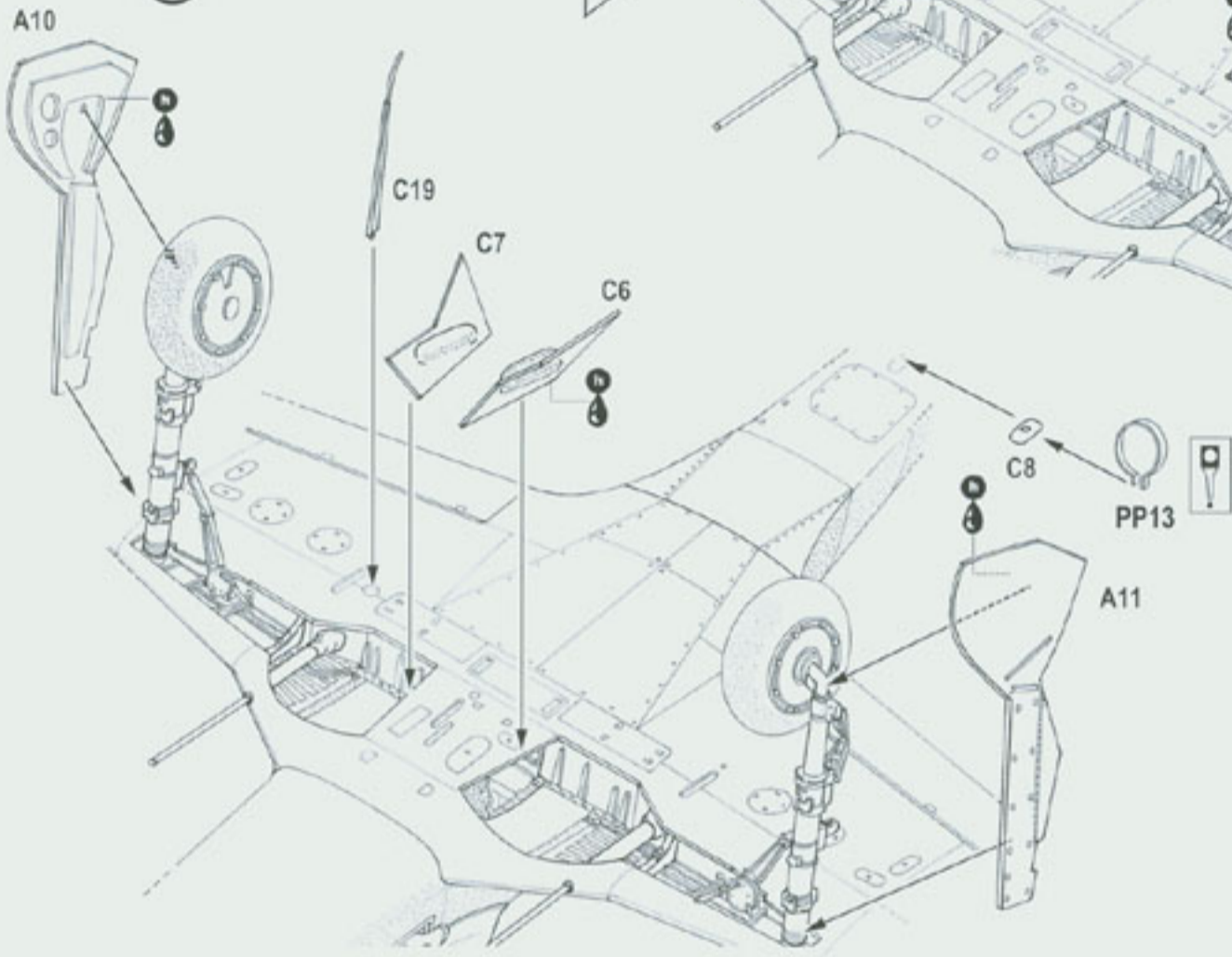

29

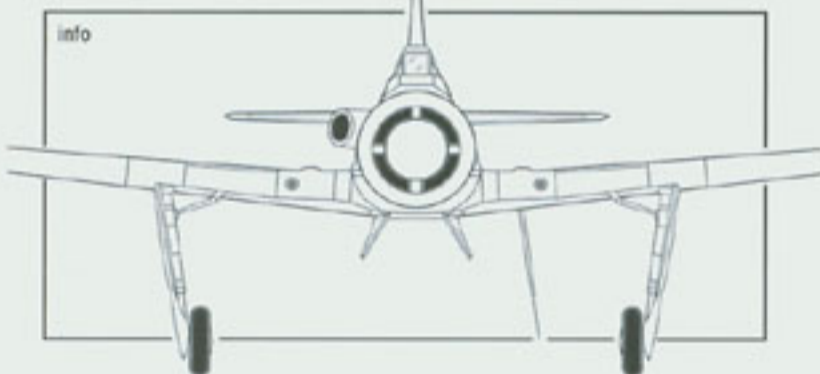
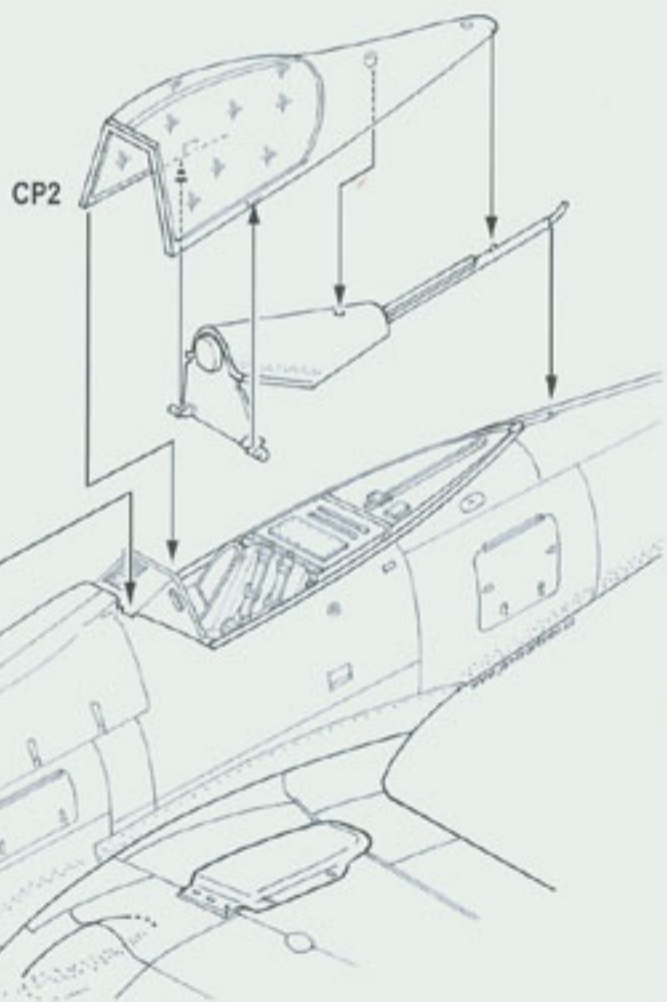

28

